

# CIRCULATION TANK HEATER

Circulation tank heaters provide dependable pre-heating for engine starts in all temperatures by circulating warmed coolant throughout the engine.

## BENEFITS

- Provides engine warming for quick, clean starts
- Reduces time to reach operating temperature
- Enhances immediate full-load acceptance
- Durable aluminum housing is corrosion and impact resistant
- Controls temperature by using a regulating thermostat
- UL Listed, UL Recognized, CSA, and CE Certified
  - \*UL Recognized (models without plugs) for OEM use only
  - \*CSA models with plugs only

## WHERE TO USE

- Diesel & Gas Gensets
- Compressors
- Agriculture

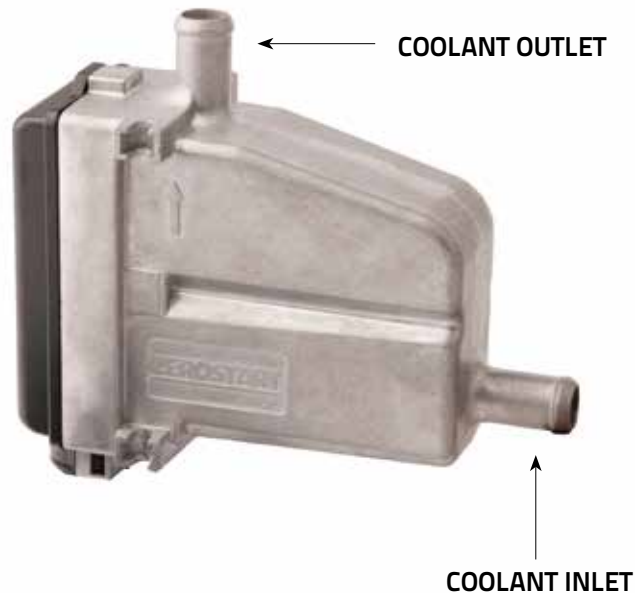

## FEATURES





- Rugged die cast, one-piece, aluminum construction
  - Regulating thermostat with automatic reset
  - Safety overheat thermostat with automatic reset
  - 5 ft. (1.52m) or 12 ft. (3.65m) power cords available
  - Available in 120, 230, 240 volt versions
- **Thermostat Ranges:**
    - 60°-80°F (16°-27°C)
    - 80°-100°F (27°-38°C)
    - 100°-120°F (38°-49°C)
  - 750W-1500W using 5/8" (16mm) hose connections and 1500W – 2250W using 3/4" (19mm) hose connections
  - Available with or without electrical plugs

**PHILLIPS & TEMRO**  
*industries*<sup>®</sup>

[www.phillipsandtemro.com](http://www.phillipsandtemro.com)

# CIRCULATION TANK HEATER

## PLUG CONFIGURATIONS

PLUG TYPE	NEMA 5-15P	NEMA 6-15P	NEMA 5-20P	CEE 7/7
	125 Volt 15 Amp	240 Volt 15 Amp	120 Volt 20 Amp	230 Volt 16 Amp
<b>Standard Male Plug</b>				

## HEATER DIMENSIONS

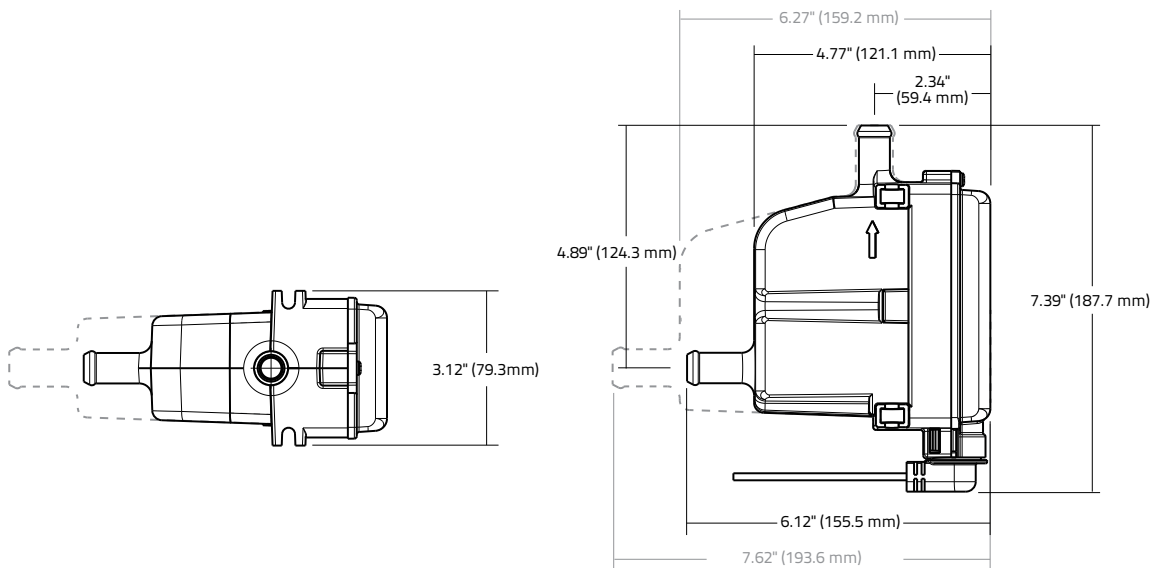

## TYPICAL MOUNTING BRACKET INSTALLATION AND DIMENSIONS (4 POSSIBLE ORIENTATIONS)

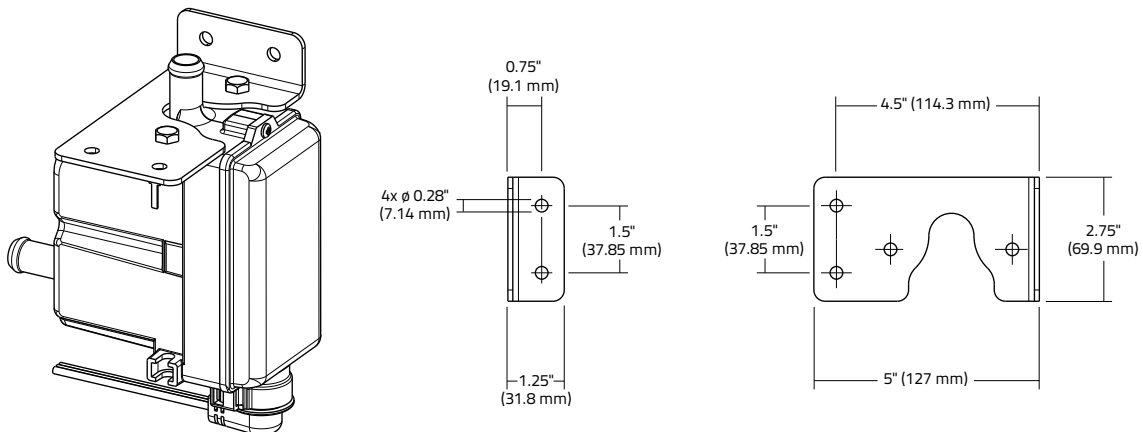

#LIT0099P ©2018 PHILLIPS & TEMRO INDUSTRIES

**PHILLIPS & TEMRO**  
industries®

[www.phillipsandtemro.com/contact/locations](http://www.phillipsandtemro.com/contact/locations)