



# In-Line Fuel & Fluid Warmers

Circulates warm coolant from the engines water pump warming the cold fuel as it circulates through the inline warmer. Installed before the primary fuel filter or transfer pump and prevents fuelgelling in the fuel line and filter.

## FEATURES

### BENEFITS

- Eliminates fuel gelling and reduces dependency on additives
- Stainless steel construction eliminate corrosion and contamination of fuel
- Flexible mounting locations

### FEATURES

- Diesel & BioDiesel up to B100 Compatible
- 304 Stainless Steel Construction
- Thermostatically Controlled Models - Prevents Fuel Overheating During All Seasons  
On 78°F Off 95°F (On 25°C Off 35°C)
- Most Versatile and Multi Purpose In-Line Warmer
- Robust design for use in extreme applications
- Mounting Brackets Included

### APPLICATIONS

- Mobile & stationary diesel engines
- On-road & off-road



I-909BT-B100



I-909BTEH-B100



I-1518BT-B100



I-1530BT-B100

# In-Line Fuel & Fluid Warmers

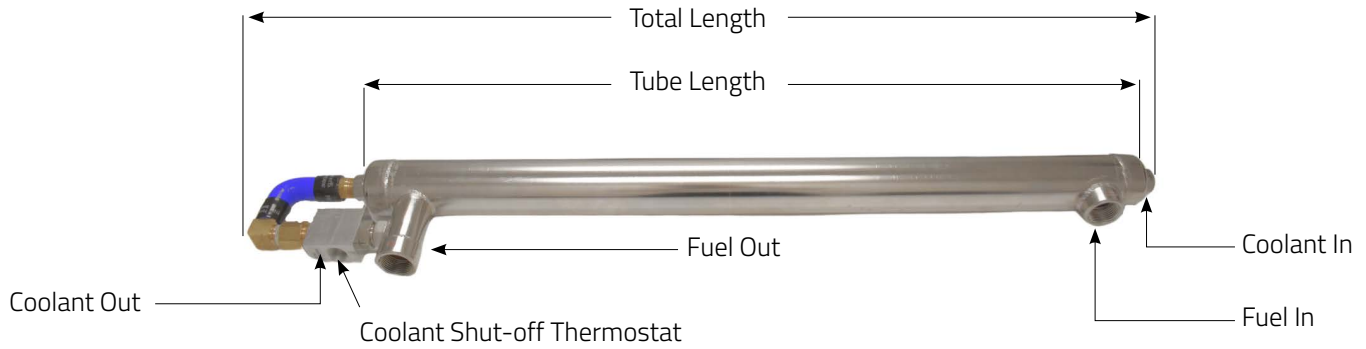

## Dimensional & Bracket Replacement Parts Information

Part No.	Fuel Port	Coolant Port	Tube Length	Tube Outer Diameter	Total Length	Surface Area	Pre Heat Option	Thermostat	Estimated HP Rating
I-702B	3/8" NPT	3/8" NPT	5-3/4" 146 mm	2" 51 mm	8-1/2" 216 mm	60 in <sup>2</sup> / 387.1cm <sup>2</sup>	-	-	180
I-703B	3/8"	1/2"	9-3/4" 248 mm	2" 51 mm	13" 330 mm	100 in <sup>2</sup> / 645.2cm <sup>2</sup>	-	-	300
I-704B	1/2"	1/2"	9-3/4" 248 mm	2" 51 mm	14" 355 mm	100 in <sup>2</sup> / 645.2cm <sup>2</sup>	-	-	300
I-909BT-B100	1/2" NPT	1/2" NPT	9-3/4" 248 mm	2" 51 mm	15-1/2" 394 mm	100 in <sup>2</sup> / 645.2cm <sup>2</sup>	-	78-95 F	300
I-909BTEH-B100	1/2" NPT	1/2" NPT	9-3/4" 248 mm	2" 51 mm	18-1/2" 470 mm	100 in <sup>2</sup> / 645.2cm <sup>2</sup>	120 VAC - 63Watts CSA Certif - Does NOT include power cord.	78-95 F	300
I-1518BT-B100	1" NPT	1/2" NPT	18" 457 mm	2-3/4" 60 mm	25-1/2" 648 mm	320 in <sup>2</sup> / 2064.5cm <sup>2</sup>	none	78-95 F	450
I-1530BT-B100	1" NPT	1/2" NPT	30" 762 mm	2-3/4" 60 mm	37" 940 mm	532 in <sup>2</sup> / 3432.3cm <sup>2</sup>	none	78-95 F	650

**NOTE:** All models made of 304 stainless steel - maximum coolant operating pressure 25 psi (172.4kPa). Pre heat option does NOT include power cord —Contact Arctic Fox for proper cord to match your application

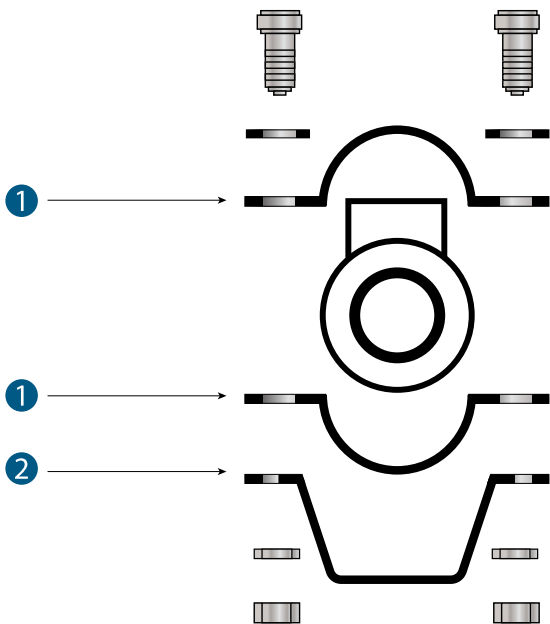

Item	Model	Part #	Description
1	I-909	A-307	Half Moon Bracket
	I-1518 / I-1530	A-1356	
2	I-909	A-308	U-Bracket
	I-1518 / I-1530	A-1361	

**NOTE:** Bracket components listed above are included with each unit in the proper quantity to support the heat exchanger.

## CORDSETS CHART

Part No.	Description	Volts	Length 1	Length 2	Silicone Connector	Plug Type
8608865	WP Single Cord	120	14' (4.3 m)	-	K	A (WP) - NEMA 5-15
8607990	WP Parallel Cord	120	7' (2.1 m)	7' (2.1 m)	K	A (WP) - NEMA 5-15
8608423	WP Parallel Cord	120	14' (4.3 m)	14' (4.3 m)	K	A (WP) - NEMA 5-15

Cordset diagrams available in HEAVY DUTY CORDSET section.

### WP SINGLE CORDSET

Single heavy-duty cord with weatherproof male plug & silicone female connector.

Plug Type A(WP)

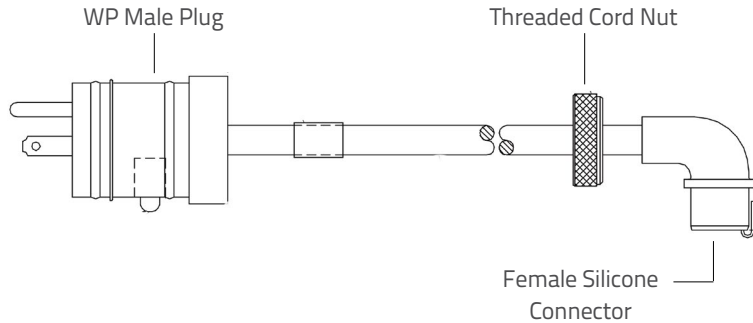
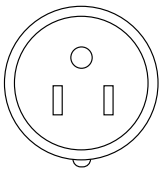

Silicone Connector - K



### WP PARALLEL CORDSETS

(2) Cords wired parallel, receiving the same voltage. Includes weatherproof male plug and (2) female silicone connectors.

Plug Type A(WP)

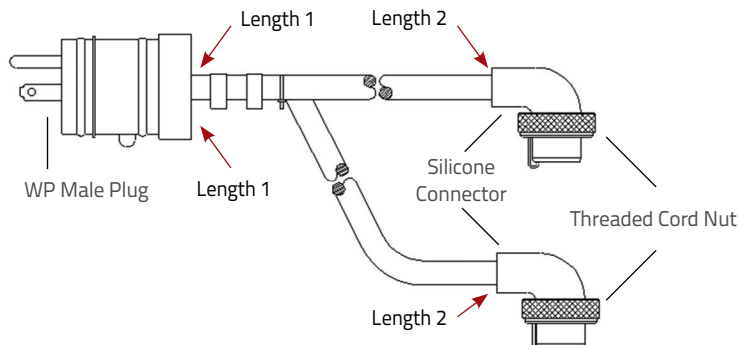
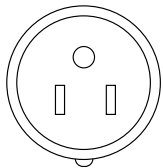

Silicone Connector - K

